

PKS-PRO-E-20-B - Servo System



FEATURES

- **Input Voltage Range of 170-253 VAC**
- **Rated Torque of 1,352 oz-in**
- **2.0 kWatt Power Rating**
- **No Load Speed of up to 1,500 RPM**
- **2,500 PPR Incremental Encoder**
- **Enclosed and Self-Cooled**
- **Oil Seal and Optional Brake**
- **MODBUS and CANopen Standard**
- **RS485 Interface**
- **Real Time Monitoring and Management**
- **Position, Speed, and Torque Control**
- **CE Certified**



DESCRIPTION

The PKS-PRO-E-20-B servo system includes a 2.0 kWatt EMG or EML AC Servo Motor operated by the PRONET-E-20A drive. These packages are ideal for quick and easy start-ups, convenience and performance! The servo motor included in this package provides torque from 1,352 oz-in. The PRONET-E drives offer current forward-feedback control, acceleration forward-feedback control, speed viewer, and inertia viewer; providing for improved response performance. These drives operate standard with MODBUS and CANopen protocol. Each system includes a 5M motor power cable, 5M encoder cable, and a 3M communication cable.

System Specs	Rated Speed (RPM)	Rated Torque (oz-in)	Rated Current (A rms)	Inertia (oz-in-sec ²)	Torque Constant KT (oz-in/A)	Resistance (ohms)	Inductance (mH)	Driver Digital Display	Brake (24VDC)	Motor Length (mm)	Shaft Diameter (mm)
PKS-PRO-E-20-A-GP22-B	2000	1352	11.3	0.3327	151.8	0.405	2.85	Yes	No	247	22
PKS-PRO-E-20-A-GP24-B	2000	1352	11.3	0.3483	151.8	0.405	2.85	Yes	Yes	289.5	22

ORDERING INFORMATION

PKS - PRO - E - 20 - A - GP 2 2 - B

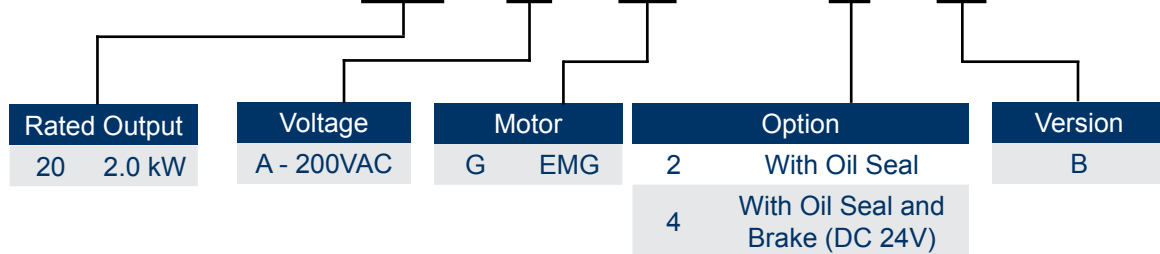

L011617

Servo Motor Specifications

FEATURES

- **Rated Torque of 1,352 oz-in**
- **3-Phase, 200VAC**
- **Rated Power up to 2.0 kWatts**
- **Peak Torque up to 300% of Rated Torque**
- **Peak Current up to 300% of Rated Current**
- **No Load Speed of up to 1,500 RPM**
- **2,500 PPR Incremental Encoder Attached**
- **Enclosed and Self-Cooled**
- **Neodymium-Iron-Boron Magnets (NdFeB)**
- **CE Certified**

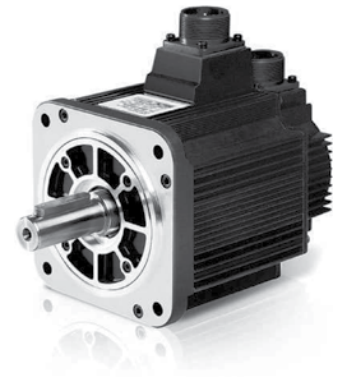

SPECS

Model #	Rated Torque (oz-in)	Rated Power (Watts)	Rated Speed (RPM)	Rated Current (A rms)	Brake (24VDC)	Inertia (oz-in-sec ²)	Electric Time Constant T _E (ms)	Back EMF Voltage K _E (V/krpm)	Torque Constant K _T (oz-in/A)	Resistance (ohms)	Weight (lbs)
EMG-20APB22	1352	2000	2000	11.3	No	0.3327	7.04	62	151.8	0.405	24.18
EMG-20APB24	1352	2000	2000	11.3	Yes	0.3483	7.04	62	151.8	0.405	31.30

DIMENSIONS

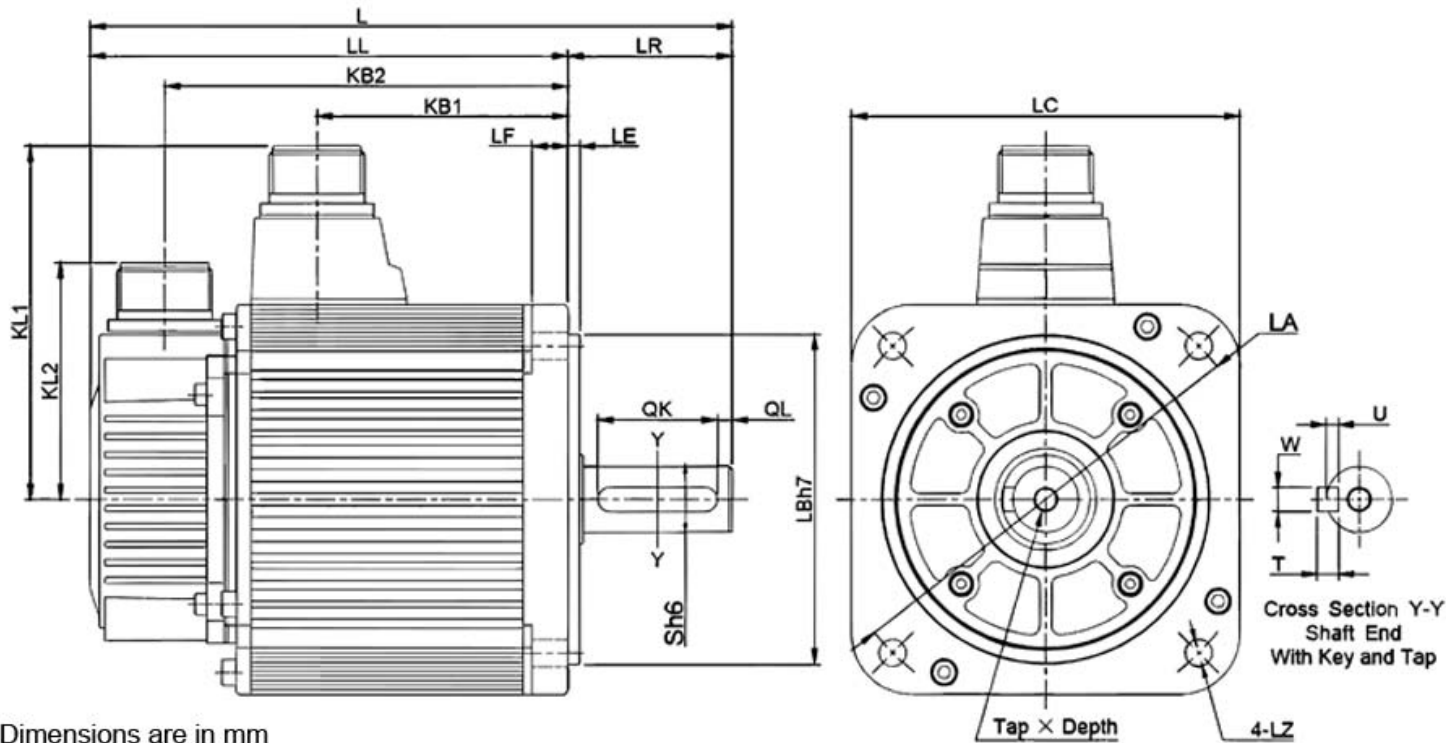

MODEL #	L	LL	KB1	KB2	KL1	KL2	FLANGE SLIDE							S	TapxDepth	KEY				
							LR	LE	LF	LC	LA	LB	LZ			QK	QL	W	T	U
EMG-20APB22	247	192	124	175.5	117	60.5	55	4	12	130	145	110	9	22	M6x20L	40	5	8	7	4
EMG-20APB24	289.5	234	147.2	218	117	60.5	55	4	12	130	145	110	9	22	M6x20L	40	5	8	7	4

PRO-E-20 - Driver Specifications

FEATURES

- Input Voltage Range of 170-253 VAC
- Rated Power up to 2.0 kWatts
- Improved Responsiveness Performance
- Enhanced Position Precision
- Low Speed Stability
- Enables Less Debugging
- MODBUS and CANopen Standard
- RS485 Interface
- Position, Speed, and Torque Control
- Homing Function



ProNet DIMENSIONS

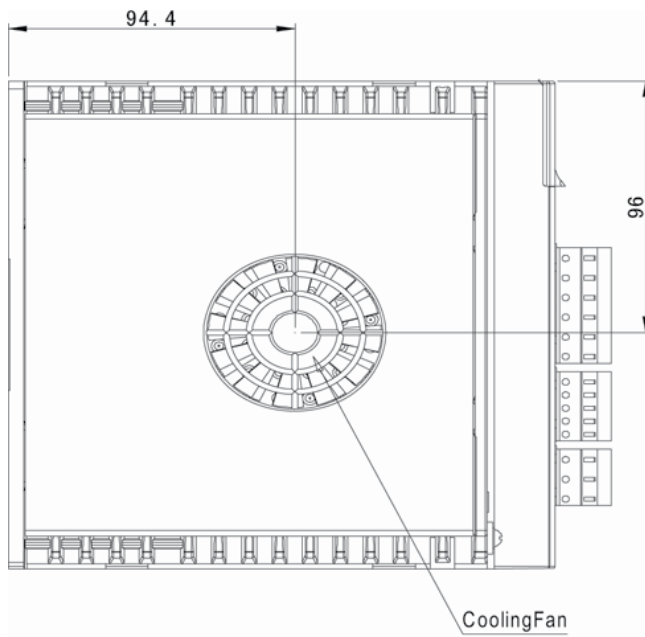

Dimensions are in millimeters (mm)

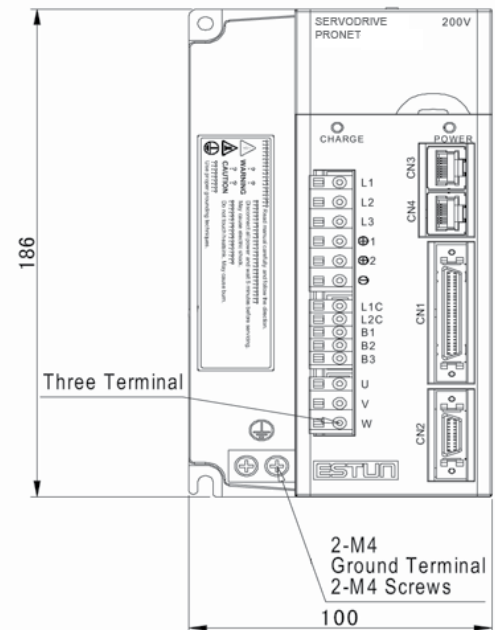

Dimensions are in millimeters (mm)

TORQUE CURVE

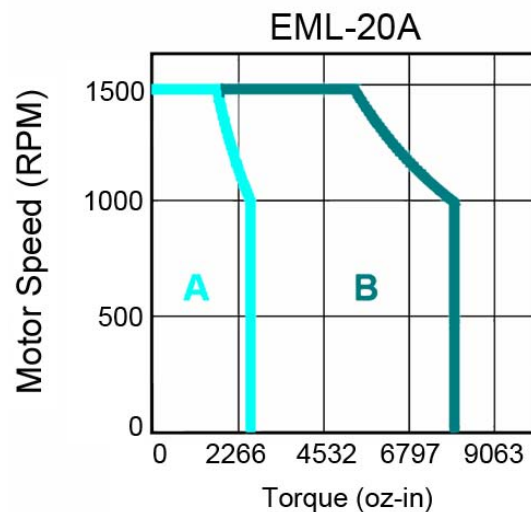
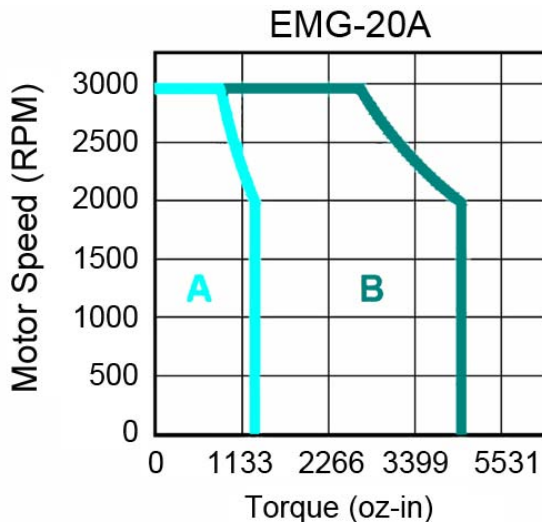

A - Continuous Working Area
B - Repeatedly Working Area

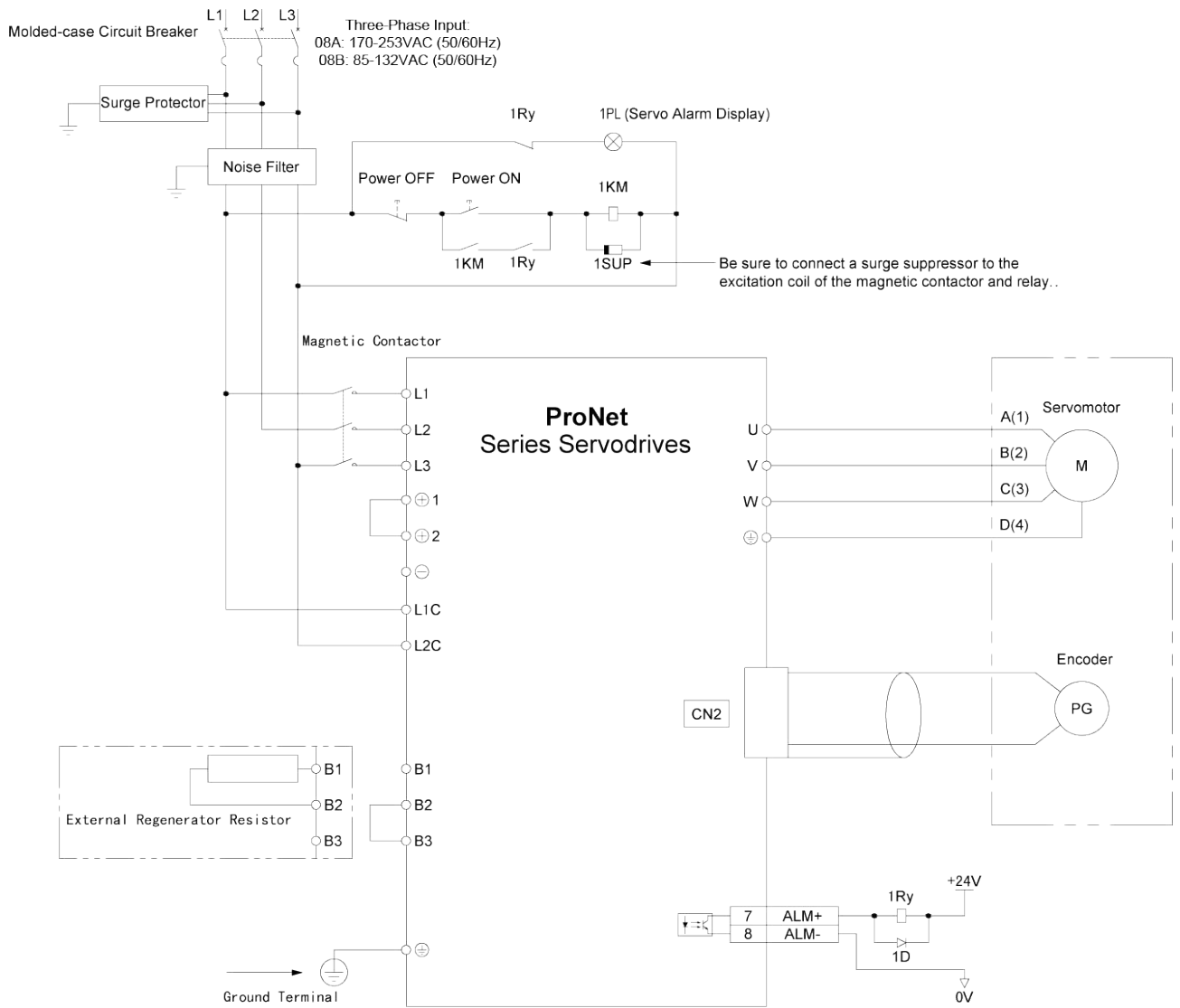

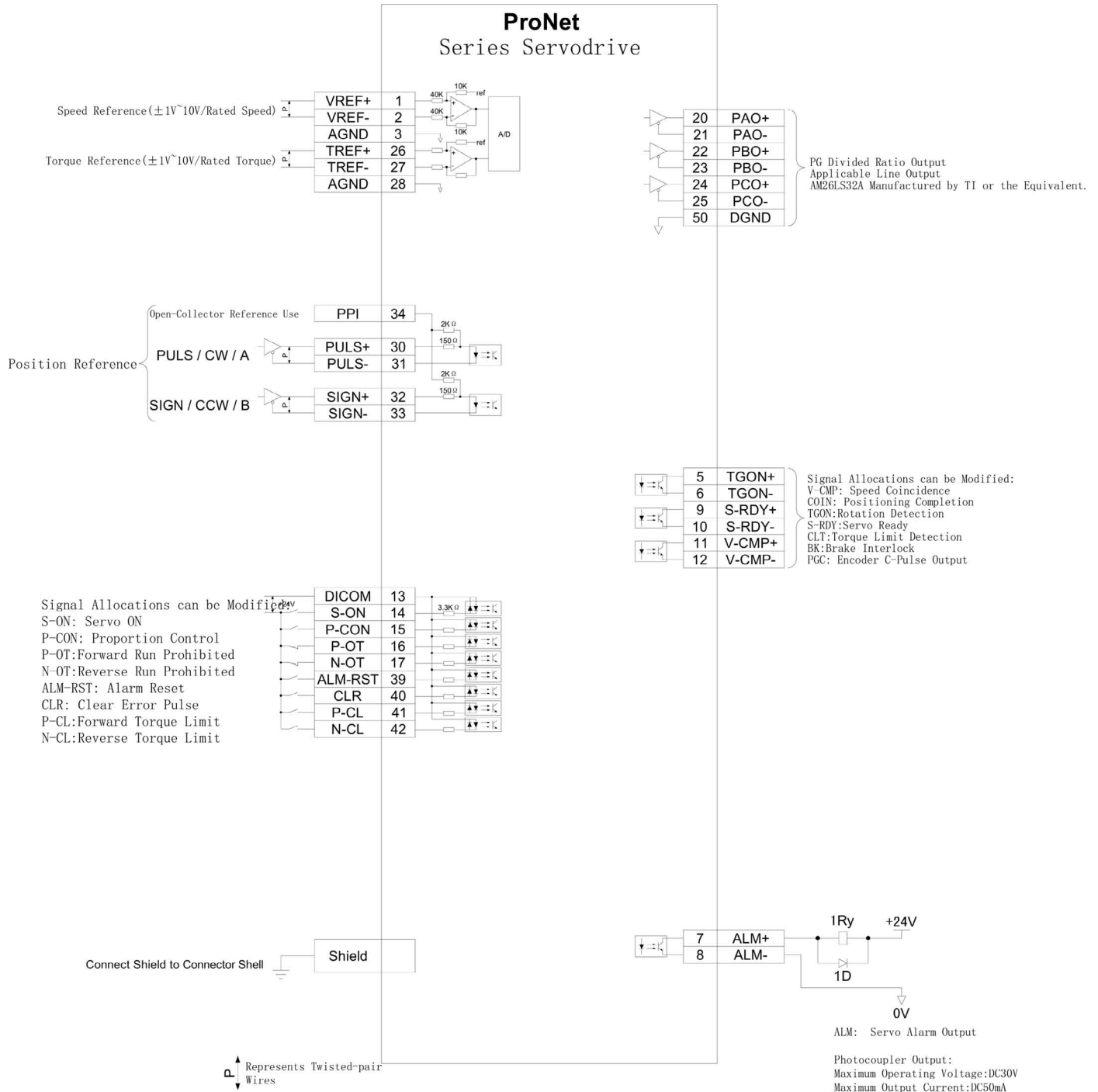

Compatible Drivers

Part Number	Description
PRONET-E-20A	2.0kW Servo Driver



Compatible Motors

Part Number	Description
EMG-20APB22	2000 RPM Servo Motor
EMG-20APB24	2000 RPM Servo Motor



Compatible Cables

Part Number	Description
PDM-GA14-05-II	Motor Power Cable
PMP-GA24-05-II	Encoder Cable
PDMB-GA14-05-II	Motor Power + Brake Cable
PRONET-PSC-CC24-02	Communication Cable

